

ORIGINAL

Section - 2

STANDARD FORMS [CONTRACT]

- *Letter of Acceptance*
- *Agreement*
- *Performance Security*
- *Advance Payment Security*
- *Retention Money Guarantee*

Note:

It is the responsibility of the bidders to comply with all the requirements given in the bidding document. Failure to non compliance with any of them may be a reason for rejection of the bid.

Notes on Standard Forms:

ORIGINAL

- Bidders shall submit the completed Form of Bid Security/Bid Securing Declaration as appropriate in compliance with the requirements of bidding documents.
- Bidders should not complete the Form of Agreement at the time of preparation of bids.
- The successful bidder will be required to sign the Form of Agreement, after the award of contract.
- Any corrections or modifications to the accepted bid resulting from arithmetic corrections, acceptable deviations, or quantity variations in accordance with the requirements of the bidding documents should be incorporated into the Agreement.
- The Form of Performance Security, Form of Advance Payment Security and Form of Retention Money Guarantee should not be completed by the bidders at the time of submission of bids.
- The successful bidder will be required to provide these securities in compliance with the requirements herein or as acceptable to the Employer.

FORM OF LETTER OF ACCEPTANCE

ORIGINAL

[Letter heading paper of the procuring entity]

-----[date]

To:-----

[name and address of the Contractor]

This is to notify you that your bid dated -----*[insert date]* for the construction and remedying defects of the ----- *[name of the Contract and identification number]* for the Contract price of -----*[name of currency]* ----- *[amount in figures and words]* as corrected in accordance with Instructions to Bidders and / or Bidders by a Memorandum of Understanding, is hereby accepted.

The adjudicator shall be -----*[name and address of the Adjudicator, if agreed]* shall be appointed by the Institute for Construction training and Development (ICTAD).

You are hereby instructed to proceed with the execution of the said Works in accordance with the Contract documents.

The Start Date shall be: ----- *(fill the date as per Conditions of Contract).*

The amount of performance Security is: -----*(fill as per Conditions of Contract).*

The performance Security shall be submitted on or before -----*(fill the date as per Conditions of Contract).*

Authorizes Signature :-----

Name and title of Signatory :-----

Name of Agency :-----

ORIGINAL

STANDARD FORM: AGREEMENT

This AGREEMENT, made the ----- [day] day of -----[month] 20 -----
[year] between the one part, and ----- [name and address of Employer]
(hereinafter called "the Employer") of the one part, and -----
-----[name and address of Contractor] (hereinafter called "the Contractor") of the other part.

WHEREAS the Employer desires that the Contractor execute-----
[name and identification number of Contract] (hereinafter called "the Works") and the Employer
has accepted the bid by the Contractor for the execution and completion of such Works and the
remedying of any defects therein.

NOW THIS AGREEMENT WITNESSETH as follows:

1. In this Agreement, words and expression shall have the same meanings as are respectively assigned to them in the Conditions of Contract hereinafter referred to and they shall be deemed to form and be read and construed as part to this Agreement.
2. In consideration of the payments to be made by the Employer to the Contractor as hereinafter mentioned, the Contractor hereby covenants with the Employer to execute and complete the Works and remedy any defects therein in conformity in all respects with the provisions of the Contract.
3. The Employer hereby covenants to pay the Contractor in consideration of the execution and completion of the Works and the remedying of defects wherein the Contract Price or such other sum as may become payable under the provisions of the Contract at the times and in the manner prescribed by the Contract.

In Witness whereof the parties thereto have caused this Agreement to be executed the day and year aforementioned, in accordance with laws of Sir Lanka.

.....
Authorized signature of Contractor

.....
Authorized signature of Employer

COMMON SEAL

COMMON SEAL

In the presence of:

Witnesses:

1. Name and NIC No.
Signature.
Address.

2. Name and NIC No.
Signature.
Address.

FORM OF ADVANCE PAYMENT SECURITY

ORIGINAL

----- [Name and address of
Agency, and Address of Issuing Branch or Office]

Beneficiary: Municipal Commissioner, Colombo Municipal Council, Town Hall, Colombo 7

Date: -----

ADVANCE PAYMENT GUARANTEE No: -----

We have been informed that ----- [name of Contractor]
(hereinafter called "the Contractor") has entered into Contract No: -----
(reference number of the contract) dated -----with you, for -----
----- (Name of contract) (hereinafter called "the Contract").

Furthermore, we understand that, according to the conditions of the Contract, an advance
payment in the sum----- [amount in figures] (-----
-----) [amount in words] is to be made against an advance payment guarantee.

At the request of the Contractor, we----- [name of issuing agency]
hereby irrevocably undertake to pay you any sum or sums not exceeding in total an amount of -
----- [amount in figures] (-----) [amount in
words] upon receipt by us of your first demand in writing accompanied by a written statement
stating that the Contractor is in breach of its obligation in repayment of the Advance payment
under the Contract.

The maximum amount of this guarantee shall be progressively reduced by the amount of the
advance payment repaid by the Contractor.

This guarantee shall expire on ----- [Insert the date, 28 days beyond the
tended Completion Date]

Consequently, any demand for payment under this guarantee must be received by us at this
office on or before that date.

[signature(s)]

FORM OF PERFORMANCE SECURITY

(Unconditional)

ORIGINAL

[Issuing

Agency's Name, and Address of Issuing Branch or Office]

Beneficiary: Municipal Commissioner, Colombo Municipal Council, Town Hall, Colombo 7

Date:-----

PERFORMANCE GUARANTEE No.:-----

We have been informed that -----[name of contractor] (hereinafter called "The contractor") has entered into Contract No. ----- (reference number of the contract) dated ----- with you, for ----- (name of contract) (hereinafter called "the Contract").

Furthermore, we understand that, according to the conditions of the Contract, a performance guarantee is required.

At the request of the Contractor, we -----[name of Agency] hereby irrevocably undertake to pay you any sum or sums not exceeding in total an amount of -----[amount in figures] (-----) [amount in words], upon receipt by us of your first demand in writing accompanied by a written statement stating that the Contractor is in breach of its obligation(s) under the Contract, without your needing to prove or to show grounds for your demand or the sum specified therein.

This guarantee shall expire, no later than the Day of -----, 20-----[insert date, 28 days beyond the Intended Completion Date] and any demand for payment under it must be received by us at this office on or before that date.

----- [signature (s)]

FORM OF RETENTION MONEY GUARANTEE

ORIGINAL

----- [Issuing Agency's
Name and Address of Issuing Branch or Office]

Beneficiary: Municipal Commissioner, Colombo Municipal Council, Town Hall, Colombo 7.

Date: -----

RETENTION MONEY GUARANTEE No: -----

We have been informed that ----- [name of Contractor]
(hereinafter called "the Contractor") has entered into Contract No. -----
(reference number of contract) dated ----- with you, for the execution of -----
----- (name of contract) (hereinafter called "the Contract").

Furthermore, we understand that, according to the conditions of the Contract, when the works have being taken over and the first half of the Retention Money has been certified for payment, payment of the second half of the Retention Money may be made against a Retention Money guarantee.

At the request of the Contractor, we ----- [name of agency]
hereby irrevocably undertake to pay you any sum or sums not exceeding in total an amount of -
----- [amount in figures] (-----) [amount in words]
upon receipt by us of your first demand in writing accompanied by a written statement stating that the Contractor is in breach of its obligation under the Contract because the Contractor has not attended to the defects in accordance with the Contract.

This guarantee shall expire, at the latest, ----- [insert 28 Days after the end of
the Defects Liability Period] Consequently, any demand for payment under this guarantee must be received by us at this office on or before that date.

[signature(s)]

7-15 (64)
5800

ORIGINAL

Section-3

CONDITIONS OF CONTRACT

**Conditions of contract shall be read in conjunction with Section 5-
Contract Data, which shall take precedence over the Conditions of
Contract**

2

0

8

CONDITIONS OF CONTRACT : Conditions of Contract that will be applicable for this Contract is that given in Section – 03 of the Standard Bidding Document – Procurement of Works (ICTAD/SBD/01-2nd Edition , January 2007) & Addendum 01 issued in January 2009 & addendum 02 issued in February 2011 to the ICTAD Publication published by the Institute for Construction Training and Development (ICTAD / CIDA – Construction Industry Development Authority , “Savsiripaya”, 123 , Wijerama Mawatha , Colombo 07.

ORIGINAL

Section 3, Volume 1 of this publication will not be issued with the Bidding Document and the Bidder is advised to purchase it from ICTAD. (Now CIDA – Construction Industry Development Authority)

Section - 4

**FORM OF BID AND QUALIFICATION
INFORMATION**

Form of Bid

Name of Contract: Repairing Storm Water Drain System at Mosque Lane, Colombo 15

To: Municipal Commissioner, Colombo Municipal Council, Town Hall, Colombo 7.

Gentleman,

1. Having examined the Standard Bidding Document – Procurement of Works [ICTAD/SBD/01 - Second Edition, January 2007], Specifications, Drawings and Bills of Quantities and Addenda for the execution of the above-named works, we the undersigned, offer to execute and complete such Works and remedy any defect therein in conformity with the aforesaid Conditions of Contract , Specifications, Drawings, Bills of Quantities and addenda nosfor the sum of Sri Lankan Rupees
.....(LKR.....) or such other sums as may be ascertained in accordance with the said conditions.
2. I/We acknowledge that the Contract Data forms part of our Bid.
3. I/We undertake, if my/our Bid is accepted, to commence the Works as stipulated in the Contract Data, and to complete the whole of the Works comprised in the Contract within the time stated in the Contract Data.
4. I/We agree to abide by this Bid **till 23.08.2022** or for any extended period and it shall remain binding upon us and may be accepted at any time before the expiration of that period.
5. Unless and until a formal agreement is prepared and executed this Bid, together with your written acceptance thereof, shall constitute a binding contract between us.
6. I/We accept I/we do not accept the Adjudicator.
7. I/We understand that you are not bound to accept the lowest or any Bid you may receive.

Dated thisday of20.....in the capacity ofduly authorized to sign tenders for and on behalf of (IN BLOCK CAPITALS)

Signature : Name:

Designation :Address :

.....

Witness Signature: Name, Address, NIC number:

.....

Qualification Information

(To be completed and submitted by the bidder, with the

ICTAD REGISTRATION	
Registration number	<i>(attach copies of relevant pages from the registration book)</i>
Grade	
Specialty	
Expiry Date	
Blacklisted Contractors	
Have you been declared as a defaulted contractor by NPA or any other Agency? (Yes/No)	
If yes provide details	
VAT Registration Number	
Construction Program	<i>(attach as annex)</i>
Legal status	<i>(attach relevant status copies, as annex)</i>
Value of Construction works performed in last 5 years	<i>(attach copies of Certificate of Completion etc and other documents such as profit-loss and income expenditure statement)</i>
Year	
Year	
Year	
Year	
Year	
Value of similar works completed in last 5 year (indicate only the three largest projects)	1. Value _____ Year 2. Value _____ Year 3. Value _____ Year <i>(attach copies of certificate of completion etc, as annex)</i>
Qualification and experience of Technical Staff at site	Technical: 1. A qualified Civil Engineer 2. A qualified Technical Officer in therelevant field (attach educational, professional, experience certificates of each person)

ORIGINAL

Section - 5

BIDDING DATA AND CONTRACT DATA

G. Bidding Data

Instructions to Bidders

ORIGINAL

Clause Reference

(1.1) The Employer is

Name: Colombo Municipal Council

Address: Town Hall, Colombo 7.

The Work consists of: Repairing of Storm Water System (Contract number ME/ME/DR/03/2022) located at: Mosque Lane, Colombo 15

(1.2) Intended Completion Date is **180 Days** from the start Date.

(1.3) The office for collection of bid form is:

Projects Management Division, Town Hall, Colombo 7.

The non-refundable fee is Rs.5400.00(including VAT)

The Bid forms will be issued **till 10.00 hours 23.02.2022**

(2.1) The source of funds is: **Colombo Municipal Council**

(4.2) The registration required

Specialty: **Storm Water Disposal and Land Drainage**

Grade: **CIDA grade C6&C7**

(4.3) The following information shall be provided in section 4:

- ❖ CIDA Registration;
Registration number
Grade
Specialty
Expiry Date
- ❖ VAT Registration number
- ❖ Construction Programme
- ❖ Legal Status (Sole Proprietor, Partnership, Company etc.)
- ❖ Qualifications and experience of key site management and technical personnel proposed for the Contract;

(4.4) a. Experience in the construction of contracts of similar nature over the last 5 years shall be 06 months.

b. Following technical & managerial Staff:

1. A qualified Civil Engineer with IESL membership and have at least 5years experience in similar nature of work.
2. A qualified Technical Officer in a related field with experience of similar nature work.

(9.1) Employer's address for the purpose of clarification is:

Name: Director Engineering (Projects)
Address: Projects Management Division, Colombo Municipal Council, Town Hall,
Colombo 07.
Fax: 0112692403
E-mail dirproj@colombo.mc.gov.lk

(11.1) The language of the bidding document shall be English.

(12.0) Any other information required to be completed and submitted with the bid.

Proof documents pertained with invitation for bids and with above 4.3, 4.4

(13.3) VAT component shall not be included in the rates. The amount written in the Form of Bid shall be without VAT. However VAT component shall be shown separately at the end of the BOQ.

(13.4) The Contract is subjected to price adjustment in accordance with Claus 47 of the Conditions of Contract.

(15.1) **The Bid shall be valid till 23.08.2022**

(16.1) Bid shall include a Bid Security using the form included in Section 9.

(16.2) Bid Security shall be:

- For an amount **Rs.171,800.00**
- **Valid until- 22.09.2022**
- Issued by a reputed Bank or Insurance Company registered to undertake businesses in Sri Lanka using the form for bid security (unconditional on demand guarantee) included in Section 9, Standard Forms.

(19.2) a. The Employer's address for the purpose of Bid submission is
Municipal Commissioner, Colombo Municipal Council,
Town Hall, Colombo 7.

(19.2) b. Contract name: Repairing Storm Water Drain System at Mosque Lane, Colombo
15
Contract no: ME/ME/DR/03/2022

(20.1) **The deadline for submission of Bids shall be till 10.00 hours on 24.02.2022**

(34.0) The performance security shall be **5%**of the Initial Contract Price mentioned in the Letter of Acceptance or as per the Public Finance Circular 03/2020(i) v. dated 11.01.2021

(36.0) The process of appointment of the Adjudicator shall be executed in accordance with the conditions of contract at a date during the contract when parties agree such an appointment is worthwhile.

Fees and types of reimbursable expenses to be paid to the Adjudicator shall be on a case to case and shall be shared by the Contractor and the Employer.

Contract Data

(Please note that the Clause nos, given hereunder are that of Conditions of Contract)

(1.0) The Employer is

Name: Colombo Municipal Council

Address: Town Hall, Colombo 7.

Name of Authorized Representative: Municipal Commissioner, Colombo
Municipal Council.

(1.0) The Engineer is

Name : Deputy Municipal Commissioner (Engineering Services)

Address : Municipal Engineers' Department, Colombo Municipal Council,
Town Hall, Colombo 7.

Name of Engineer's Representative: Director Engineering (Projects),
Colombo Municipal Council.

(1.0) The works consists of Repairing of Storm Water System

Contract number is ME/ME/DR/03/2022

The Site is Located at Mosque Lane, Colombo 15

(1.0) The Start Date shall be **21 days** from the Letter of Acceptance

(2.2) Sectional Completion of work is specified as follows.

Not applicable

(2.3) The following documents also form part of the Contract: **Not applicable**

(8.1) Schedule of other contractors: **None**

(9.1) Schedule of key personnel:

Minimum persons with qualifications and experience to be defined,

- 1. A qualified Civil Engineer with IESL membership and have at least 5years experience on project in similar nature of work.**
- 2. A qualified Technical Officer in a related field with experience of similar nature work.**

(13.1) The minimum insurance covers shall be (shall be valid till the end of defect liability period of the contract. It is the responsibility of the contractor to extend the validities of insurance covers for any extended time of defect liability period without any notification by the employer):

- (a) * The minimum cover for insurance of the Works and of plant and Materials is 110% of Initial Contract Price
- The maximum deductible for insurance of the Works and of Plant and Materials is 5% of Initial Contract Price
- (b) * The minimum cover for loss or damage to Equipment is 5% of Initial Contract Price
- The maximum deductible for insurance of Equipment is 5% of Minimum cover.
- (c) * The minimum cover for insurance of other property (other than the site) is 5% of Initial Contract Price.
- (d) The minimum cover for personal injury or death,
- * for third party and employees of the Employer and other Persons engaged by the Employer in the Works is Rs. 200,000.00 per event.
- (13.2)** The minimum cover for personal injury or death shall be (shall be valid till the end of defect liability period of the contract. It is the responsibility of the contractor to extend the validities of insurance covers for any extended time of defect liability period without any notification by the employer)
- for the Contractor's workmen is Rs. 200,000.00 per event
 - Contractor's employees other than workmen are Rs. 200,000.00 per event.
- (14.1)** The following site investigation reports are annexed as Appendices:
- No appendices**
- (17.1)** The intended Completion Date for the whole of works shall be **180 days**
- (21.1)** The site Possession Date shall be **14 Days** from Letter of Acceptance
- (27.1)** The Contractor shall submit a programme for the works within **14 days** of delivery of the Letter of Acceptance.
- (27.3)** The Contractor shall submit updated program of work for every ----- days.
Not applicable
- (27.4)** Withholding amount for not complying with above 27.1 & 27.3. Not applicable
- (35.1)** The Defects Liability Period is **365 Days**
- (39.2)** Engineer may order variations in such a way that contract value of the project is not exceeded.
- (47.1)** The contract price is **subjected to price adjustment**

Formula used to calculate price Fluctuation

$$F = 0.869 \times (V - V_{na}) \times \frac{(I_{tc} - I_{tb})}{I_{tb}}$$

$$V = (V_c + M_c) - (V_p + M_p)$$

$$V_{na} = (V_{nac} - M_{nap})$$

The following elements do not consider for the Price fluctuations.

- Preliminaries (Item 1.1 to 1.33)
- Demolishing works (item 2.3)
- Provisional Sum Items
- Items (2.8)
- Additional Work

- (48.1)** The retention from each payment shall be **10%** of the certified work done. The limit of retention shall be **5%** of the Initial Contract price.
- (49.1)** The liquidated damages for the whole of the works shall be **5000** per Day. The maximum amount of liquidated damage for the whole of the Works shall be **10%** of the Contract price.
- (51.1)** Contractor shall be paid an advance payment only on submission of an unconditional Bank Guarantee obtained from a reputed Bank registered in Central Bank of Sri Lanka. The value of the Bank guarantee shall be equivalent to the eligible amount calculated as per conditions of contract and it shall be valid till the end of intended completion date or an extension of intended completion date. Contractor shall extend the validity of the Bank guarantee for extension of intended completion date without any notification by the employer. Employer shall demand the advance payment guarantee for such failure of the contractor to extend its validity without any notification to the contractor.
- (52.1)** The performance security shall be **5%** or as per the Public Finance Circular 03/2020(i) v. of the Initial Contract Price. This security shall be unconditional on demand and of the Initial Contract Price. This security shall be unconditional on demand and valid till 28 days beyond the intended completion date or any extended intended completion date. Contractor shall extend the validity of performance security for any extension of intended completion date without any notification by the employer. Employer shall demand the performance security for such failure of the contractor to extend its validity without any notification to the contractor.
- (60.1)** The percentage to apply to the value of the work not completed, representing the Employer's additional cost for completing the Works, is **25%**

ORIGINAL

Section - 6

SPECIFICATIONS

**(General specifications have been mentioned in drawings
and Bills of Quantities)**

(51) ✓
ORIGINAL

• Section - 7

• **BILLS OF QUANTITIES**

- 1. Include Preliminary Bill items as Bill No. 1**
- 2. VAT Component shall be filled in Bills of Quantities and it shall not be carried to Form of Bid.**
- 3. Any discount offered will not be considered for Provisional Sum Items**

COLOMBO MUNICIPAL COUNCIL
MUNICIPAL ENGINEER'S DEPARTMENT

PROJECT: PEPAIRING STORM WATER DRAIN SYSTEM AT MOSQUE LANE, COLOMBO -15.

ITEM	DESCRIPTION	UNIT	QTY.	RATE	AMOUNT
	Bill No 01				
1.0	Preliminaries				
1.1	Provisional sum for providing Performance security.			Provisional sum	7,000.00
1.2	Provisional sum for providing an Advance Payment security.			Provisional sum	30,000.00
1.3	Provisional sum for insurance of the works,Machinery & equipment, Plant, Materials, third party persons & property and Employer's personnel & property at site as per contract.			Provisional sum	25,000.00
1.4	Provisional sum for insurance of against accident and injury to contractor's personnel as per th contract..			Provisional sum	10,000.00
1.5	Contractor's Facilities Allow lump sum for constructing, maintaining, dismantling and removal on completion of the works, a temporary site office of adequate size including staff rest roomand toilets and other facilities for the contractor's site management staff in accordance with the plans prepared by the Contractor and concurred by the Engineer.	Item			

ITEM	DESCRIPTION	UNIT	QTY.	RATE	AMOUNT
1.6	Allow lump sum for constructing, maintaining, dismantling and removal on completion of the works, building to be used as workshops and stores for perishable materials. Buildings shall be constructed in accordance with the drawing prepared by the Contractor and concurred by the Engineer. The lump sum shall also include for altering, modifying or dismantling and re-erecting within the site all temporary buildings/structures if required.	Item			
1.7	<p>Allow lump sum for constructing, maintaining, dismantling and removal on completion of the works, temporary building to in accordance with the plans prepared by the Contractor and concurred by the Engineer to accommodate by the following:</p> <p>a) Workers' rest room, canteen facilities, kitchen</p> <p>b) Toilet & wash areas.</p> <p>c) Sick/First - Aid room</p> <p>d) Accomadation for Contractor's staff and workmen including sanitary facilities on site of applicable.</p> <p>Facilities to workmen shall conform to the latest public health and industrial regulation.</p>	Item			
1.8	Allow lump sum for providing Accomadation including sanitary facilities and transport Contractor's staff and workment off site.	Item			
1.9	Allow lump sum for providing telephone and facsimile facilities, electricity and water services for the contractor's site office for their use in connection with the works.	Item			

ITEM	DESCRIPTION	UNIT	QTY.	RATE	AMOUNT
1.10	Allow lump sum for maintenance, rental, consumption charges etc. for telephone and facsimile facilities, electricity and water services for the contractor's site office for their use in connection with the works.	Item			
1.11	Allow lump sum for contractor's transport facilities at site.	Item			
	<u>SETTING OUT</u>				
1.12	Allow lump sum for employing a licensed land surveyor to define the bulding site work stc.,check levels and carry out such other surveys as may be necessary to establish accurately the placing of forms and pouring of concrete and all other setting out in both vertical and horizontal plane.	Item			
1.13	Allow lump sum for setting out of works in accordance with drawing and other written information given by the Engineer.	Item			
	<u>QUALITY, STANDARDS & PROGRESS</u>				
1.14	Allow Lump sum for provision of progress report photographic record and other schedules including in the ICTAD publication- Guideline for Effective Construction Management. (ICTAD/CM/01), relevant to contract administration as directed by the Engineer.	Item			
1.15	Allow lump sum for all cost in connection with preparing samples for testing, making arrangement for testing of materials, goods etc, as stipulated in the specification, obtaining test reports and submitting the same to the Engineer.	Item			

ITEM	DESCRIPTION	UNIT	QTY.	RATE	AMOUNT
1.16	Allow lump sum for provision of shop drawings, bar schedules etc. for Engineer's approval.	Item			
1.17	Allow lump sum for provision of 2 sets of (hard copies and soft copies) as-built drawings of all services, for Engineer's approval.	Item			
<u>Health, Safety & Environment</u>					
1.18	<p>Allow lump sum for following services throughout the period of construction for Engineer's office, contractor's site office and worker's rest room and other facilities;</p> <p>a) Employing Workmen to clean and maintain all areas to be in good hygienic conditions including toilets, wash areas, kitchen etc. rest room, canteen facilities, kitchen</p> <p>b) Supplying adequate drinking water, water for washing purposes, soap, detergent, etc. throughout the period of construction.</p>	Item			
1.19	Allow Lump sum for providing all necessary safety measures to workmen at site conforming to the latest industrial safety regulation and as directed by the Engineer.	Item			
1.20	Allow Lump sum for making adequate provision against air and noise pollution of surrounding areas. Hoarding and dust screens shall be provided to control dust escaping to surrounding areas.	Item			
1.21	Allow Lump sum for maintaining the site in a clean and orderly manner at all times and during the entire contract period.	Item			

ITEM	DESCRIPTION	UNIT	QTY.	RATE	AMOUNT
1.22	Allow Lump sum for demobilization, removal of all rubbish & debris and clearing up site on completion, leaving all in good order and handing over.	Item			
1.23	Allow Lump sum for employing an adequate number of security personnel and security system on full time basis throughout the period of construction, and provide for necessary security lighting and a warning system.	Item			
1.24	Allow lump sum for providing and maintaining necessary fencing, hoarding, and gates for safeguarding the works, materials and plant as directed by the Engineer.	Item			
1.25	Allow lump sum for protection of public and private services at site. The contractor shall take due care to protect, water supply and drainage systems, telephone and overhead/buried electrical cables etc. whose location are identified and made available to the bidder at the time of bidding, unless earmarked for demolition, during the execution of the works. the contractor is to make good any cause within his control at his own expense or pay any cost and charges in connection therewith.	Item			
1.26	Allow lump sum for supply of water for the works and paying all charges and other expenses in connection with the supply from water mains or any other alternative method of water supply, storage and reticulation.	Item			
1.27	Allow lump sum for supplying temporary electricity for the works including connection, distribution system for the works, internal arrangements and all payments to the authorities for consumption.	Item			

ITEM	DESCRIPTION	UNIT	QTY.	RATE	AMOUNT
1.28	Allow lump sum for providing hoisting equipment and other plant for the use of the works on site(dry hire).	Item			
1.29	Allow lump sum for providing small machinery and equipment for the use of the works at site.	Item			
1.30	Allow lump sum for erecting and maintaining scaffolding and/or self climbing platforms. Such scaffolding etc. shall be removed on completion and all works disturbed shall be made good.	Item			
1.31	Allow lump sum for stamp duty in accordance with the prevailing regulations of the Government.	Item			
1.32	Allow lump sum for providing and maintaining a name board to the specifications and/or directed by the Engineer.	Item			
1.33	Allow lump sum for excavation for trial pits/trial trenches as specified or as directed by th engineer as for location services etc. and reinstating the ground and making good disturbed work to the satisfaction of the Engineer.	Item			
	Total Preliminaries carried over to summary				

MUNICIPAL ENGINEER'S DEPARTMENT
COLOMBO MUNICIPAL COUNCIL

PEPAIRING STORM WATER DRAIN SYSTEM AT MOSQUE LANE, COLOMBO -15.

ITEM	DESCRIPTION	QTY	UNIT	RATE	AMOUNT
	<p>Note:-</p> <p>1. All the items below rate included for supplying of materials.</p> <p>2. Prior to do pricing the contractor is advised to do a detail inspection of the site.</p>				
2.0	<p>Bill No - 02</p> <p>Note :- Road Cutting Permit should be taken by the contractor from the Central Road Maintenance Unit (CRMU of CMC)</p>				
2.1	<p>Removing of pre-mixed surface and temporary reinstatement dealing with all existing utility services.</p> <p>Note: Permanent reinstatement should be done by CRMU of CMC and reinstatement cost has to be paid to CRMU separately by the contractor.</p>	m ²	5.0		-
2.2	<p>Permanent reinstatement of damage bitumen surface in pre-mixed road.</p>	Provisional sum			72,625.00
2.3	<p>Demolishing existing shop, concrete drains, hume pipes, cover slabs and removing debries away from the site.</p>	Item	Allow	Sum	
2.4	<p>DRAIN WORK</p> <p>Item shall include, excavation in trenches, preparation of surfaces, Removal of excess earth, form work, shoring, dewatering, backfilling and compaction with suitable available or imported materials by 150mm thick compacted layers Lay and join to complete working order.</p>				
2.4.1	<p>HALF ROUND CHANNEL</p>				
2.4.1.1	<p>Providing and placing 50mm thk 1:3:6(25mm) screed concrete and 75mm thk 1:2:4(20mm) grade 20 concrete bed to place 300mm dia single reinforced Half Round Channels fixed with 1:2 cement:sand plaster to approved gradient. Rate to include for raise the walls in both sides with Grade 20 concrete.(As per the</p>				
2.4.1.1	<p>Depth not exceeding 1.0m</p>	Lm	166.00		-

ITEM	DESCRIPTION	QTY	UNIT	RATE	AMOUNT
2.4.1.2	Providing and placing 50mm thk 1:3:6(25mm) screed concrete and 75mm thk 1:2:4(20mm) grade 20 concrete bed to place 450mm dia single reinforced Half Round Channels fixed with 1:2 cement:sand plaster to approved gradient. Rate to include for raise the walls in both sides with Grade 20 concrete.(As per the				
2.4.1.	Depth not exceeding 1.0m	Lm	16.00		-
2.4.2	COVER SLABS				
2.4.2.1	Casting, curing and placing of 600x450x150mm dimension 1:2:4(20) RCC cover slabs. (As per the detail drawing - A)	Nos	369.00		-
2.4.2.2	Casting, curing and placing of 750x450x150mm dimension 1:2:4(20) RCC cover slabs. (As per the detail drawing - B)	Nos	36.00		-
2.5	PIPE WORK				
	Item shall include, excavation in trenches, preparation of surfaces, Removal of excess earth, form work, shoring, dewatering, backfilling and compaction with suitable available or imported materials by 150mm thick compacted layers. Lay and join to complete working order.				
	300mm dia NP2 Hume pipes to approved gradient on concrete base. (Concrete will be paid separately) (As per the detail drawing - C)				
2.5.1	Invert depth upto 1.0m	Lm	5.00		-
2.6	GULLY (WITH GRATING ON TOP)				
	500 x500 mm internal dimensions, 75mm thick base with 1:3:6(25) cement concrete & 150 mm thick base and walls with 1:11/2:3(20mm) concrete rectangular gully. (Rate to include for excavation, back filling & compaction, form work). Concrete walls should have a satisfactory smooth finish. Supply & fix D400 type DI grating Frame comply with BS.EN .124 on top, and connection to drain as per the instructions.				
2.6.1	Invert depth not exceeding 1.0m	Nos.	4.00		-
2.7	CONCRETE				
2.7.1	1:2:4(20mm) cement concrete in surrounding along the 375mm diameter pipes. Rate shall include Form work. (As per the drawing -B)	m ³	1.30		-
2.8	DIVERSION				
	Storm water flow diversion during the construction period.	Item	Allow	Sum	
2.9	Protection of other services. (Rate shall include for precautions to these service lines or diverting them and repairs to structures if it is damaged due to construction processes.)		Provisional sum		100,000.00
	TOTAL				

ORIGINAL

17

17

SUMMARY	
Bill No 01 Preliminaries	
Bill No-2 Strom Water Drain	
Sub Total	
10% Contingencies	
5% Fluctuation	
Grand Total	
8% VAT	
Project Amount	

Bidder's Signature

.....

ORIGINAL

Section -8

DRAWINGS

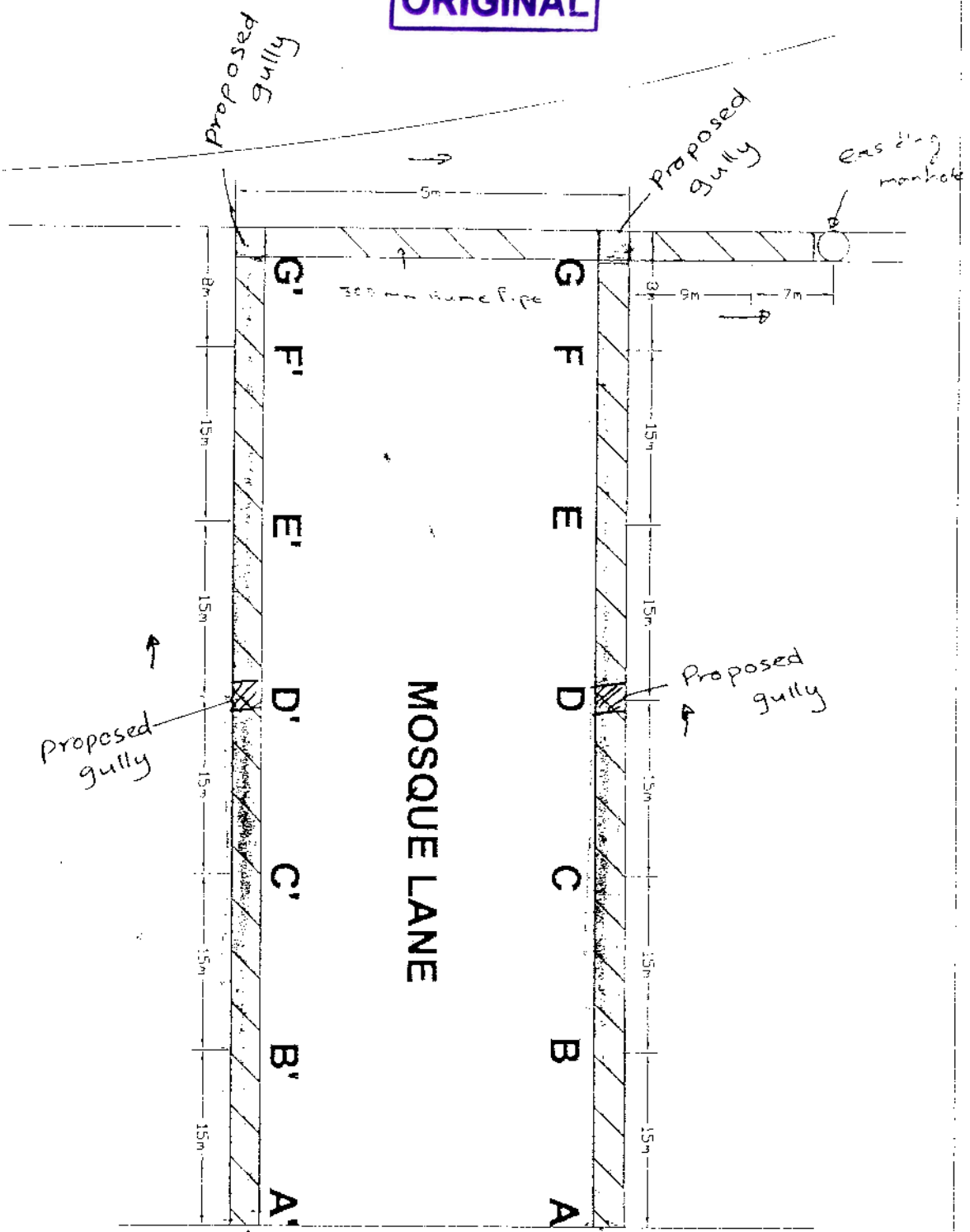

ORIGINAL



SITE PLAN

MUTHUWELLA MAWATHA

NOTE:

-  PROPOSED DRAIN
300mm Half Round
-  PROPOSED DRAIN
450mm Half Round
-  PROPOSED GULLY

PROJECT : REPAIRING STORM WATER DRAIN SYSTEM AT MOSQUE LANE, COL MBO-15.

ORIGINAL

Scale
1:100

DRAWN BY: G. Thanthira
 DESIGNED BY: S.P. Chakkayilam (Exe. Design)
 CHECKED BY: I.A. Dama (S.D. Proj. Design)
 APPROVED BY: M.J.M. Saloor (Director, Planning)
 DATE: 19/02/2020
 DRAWING NO: 06-15-22

Legend
 — Existing Ground Level
 — Existing Invert Level
 — Proposed Drain

DRAWING TITLE : LS/02

PROJECT : REPAIRING STORM WATER DRAIN SYSTEM AT MOSQUE LANE, COLOMBO-15. (LEFT SIDE)

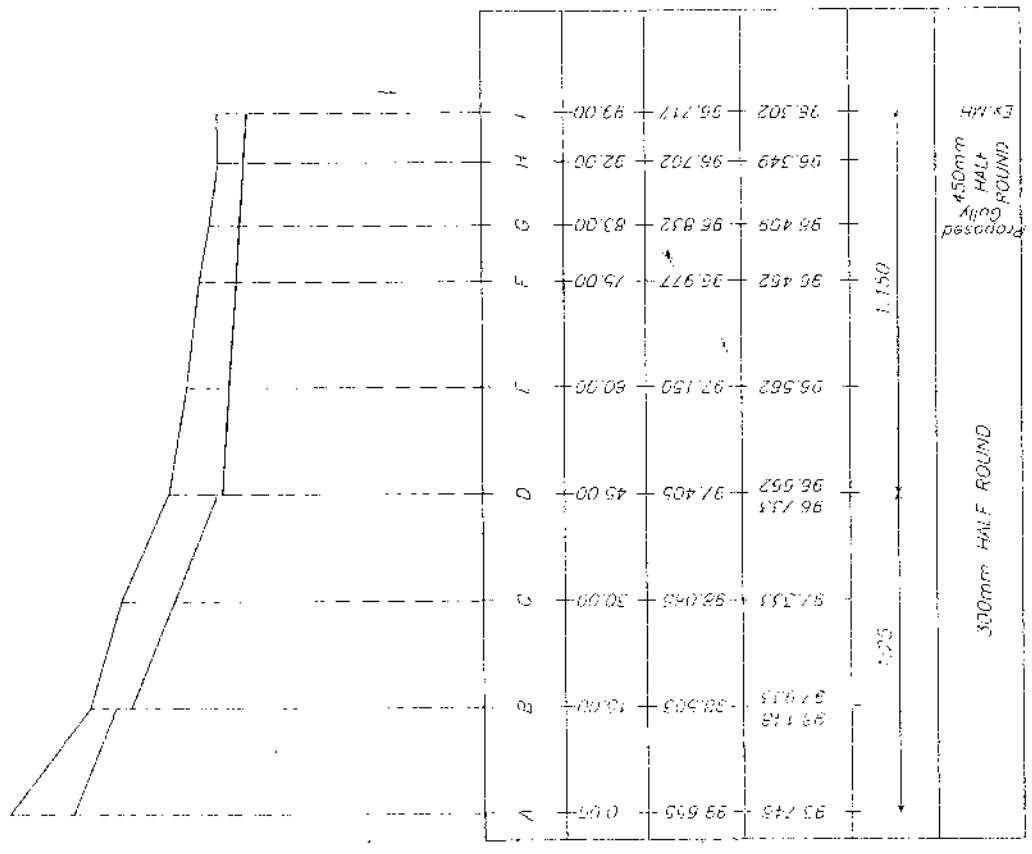

DATUM 93.00

POINT	DISTANCE (m)	GROUND LEVEL (m)	INVERT LEVEL (m)
A	0.00	99.600	99.748
B	10.00	98.903	99.118
C	30.00	98.048	97.551
D	45.00	97.405	96.733
E	60.00	97.150	96.568
F	75.00	96.977	96.452
G	83.00	96.852	96.408
H	92.00	96.702	96.349
I	99.00	96.217	96.302

PROJECT : REPAIRING STORM WATER DRAIN SYSTEM AT MOSQUE LANE, COLOMBO-15. (LEFT SIDE)

DRAWING TITLE : LS/02

Legend

— Existing Ground Level
 — Existing Invert Level
 — Proposed Drain

DRAWN BY: G. Thanthira
 DESIGNED BY: S.P. Chakkayilam (Exe. Design)
 CHECKED BY: I.A. Dama (S.D. Proj. Design)
 APPROVED BY: M.J.M. Saloor (Director, Planning)
 DATE: 19/02/2020
 DRAWING NO: 06-15-22

Legend

DRAWING TITLE : LS/02

PROJECT : REPAIRING STORM WATER DRAIN SYSTEM AT MOSQUE LANE, COLOMBO-15. (LEFT SIDE)

ORIGINAL

Scale
1:100

DESIGNED BY: S.P.C. Illakkumbum (Hyg Design)
 CHECKED BY: H.A. Sarin (O.D. Eng. Design)
 APPROVED BY: M. L.M. Rajeev (Director Drainage)
 DATE: 14/02/2020
 DRAWING NO: DR-15/01

Legend
 - - - Existing Ground Level
 - - - Existing Invert Level
 - - - Proposed Drain

DRAWING TITLE: LS 101

PROJECT: REPAIRING STORM WATER DRAIN SYSTEM AT MOSQUE LANE, COLOMBO-15. (RIGHT SIDE)

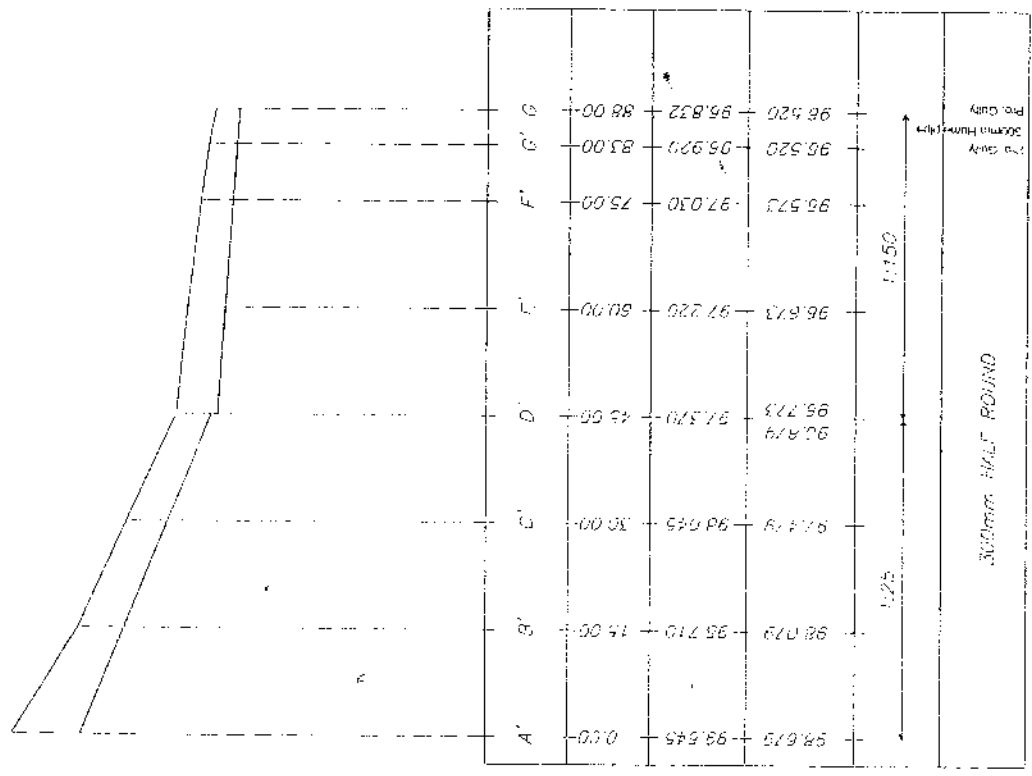

DATUM: 93.00

POINT	A'	B'	C'	D'	E'	F'	G'	G'
DISTANCE (m)	0.00	15.00	30.00	45.00	60.00	75.00	83.00	88.00
GROUND LEVEL (m)	98.675	98.079	97.479	96.879	96.273	95.673	95.079	95.420
INVERT LEVEL (m)	98.545	95.710	96.045	97.370	97.220	97.030	96.920	95.832

PROJECT: REPAIRING STORM WATER DRAIN SYSTEM AT MOSQUE LANE, COLOMBO-15. (RIGHT SIDE)

DRAWING TITLE: LS 101

Legend

- - - Existing Ground Level
- - - Existing Invert Level
- - - Proposed Drain

DESIGNED BY: S.P.C. Illakkumbum (Hyg Design)
 CHECKED BY: H.A. Sarin (O.D. Eng. Design)
 APPROVED BY: M. L.M. Rajeev (Director Drainage)
 DATE: 14/02/2020
 DRAWING NO: DR-15/01

DESIGNED BY: S.P.C. Illakkumbum (Hyg Design)
 CHECKED BY: H.A. Sarin (O.D. Eng. Design)
 APPROVED BY: M. L.M. Rajeev (Director Drainage)
 DATE: 14/02/2020
 DRAWING NO: DR-15/01

ORIGINAL

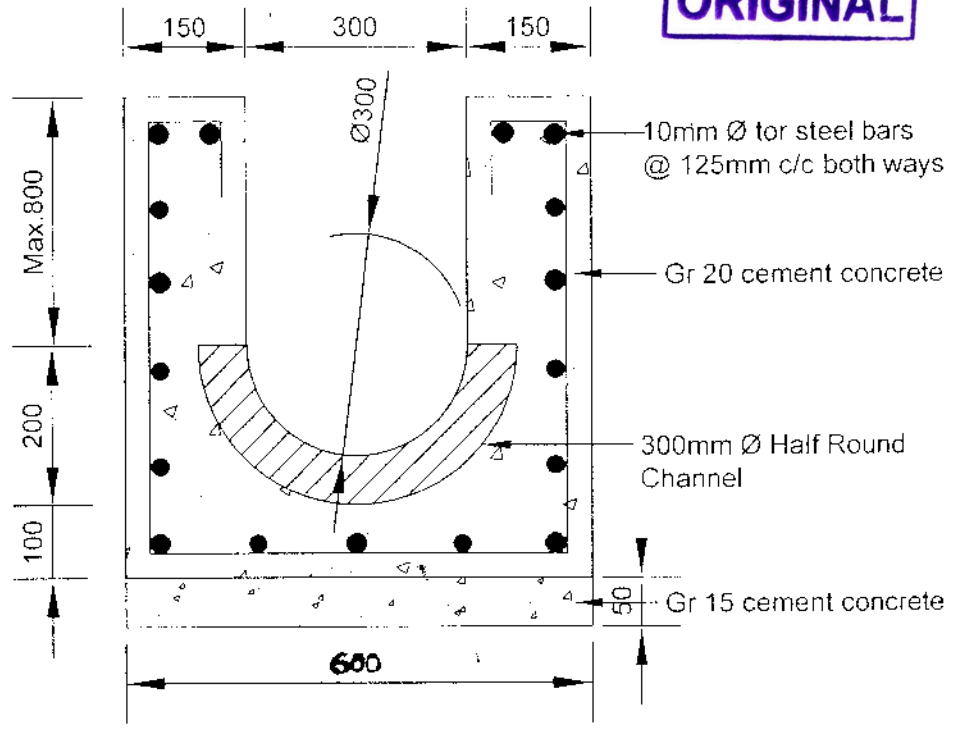

SECTION OF HALF ROUND CHANNEL

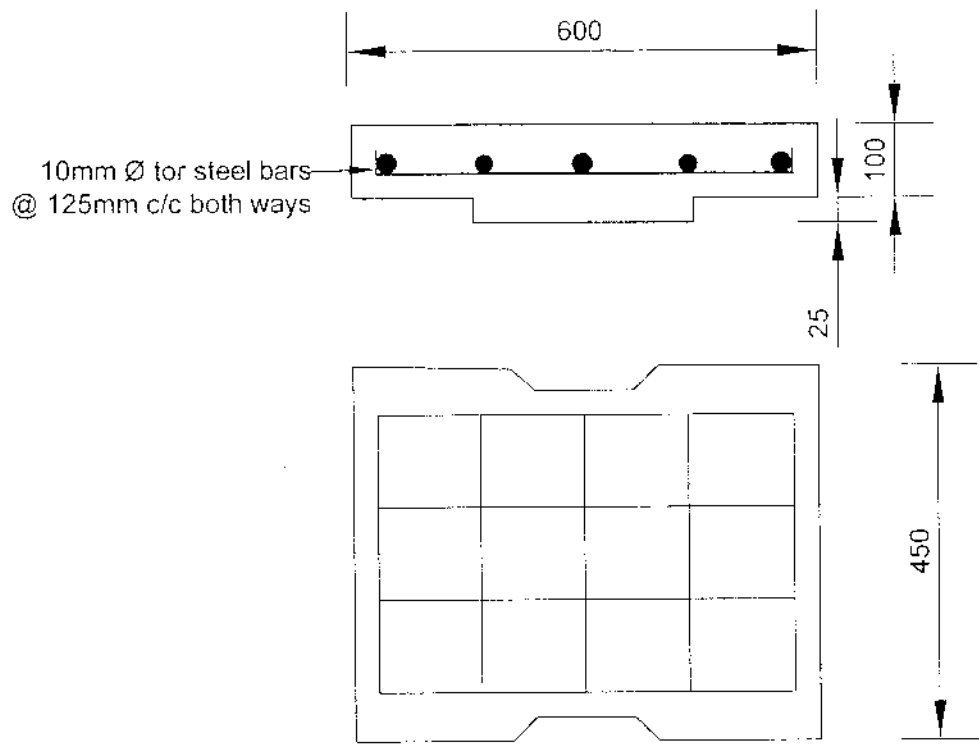

NOTE
ALL DIMENSIONS ARE IN MILLIMETERS

COVER SLAB

HALF ROUND CHANNEL WITH COVER SLAB

(DRAWING - A)

HALF ROUND CHANNEL WITH COVER SLAB

COVER SLAB

NOTE
ALL DIMENSIONS ARE IN MILLIMETERS

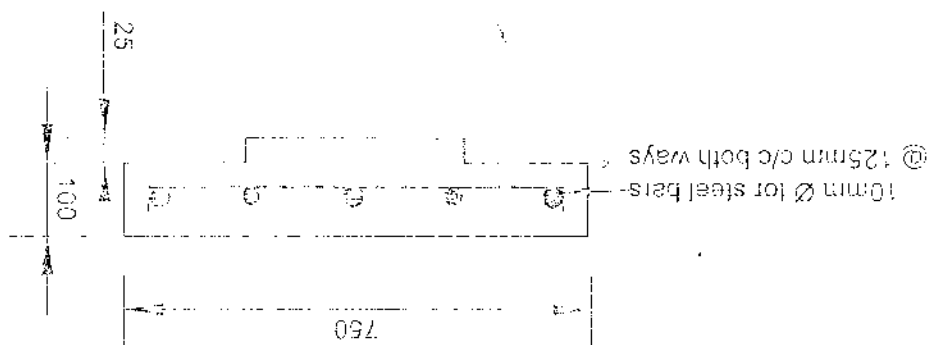
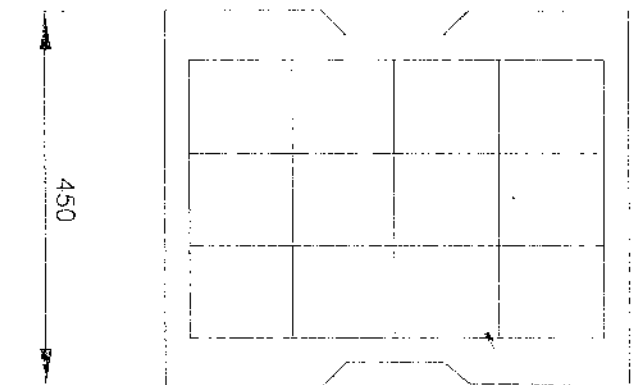

SECTION OF HALF ROUND CHANNEL

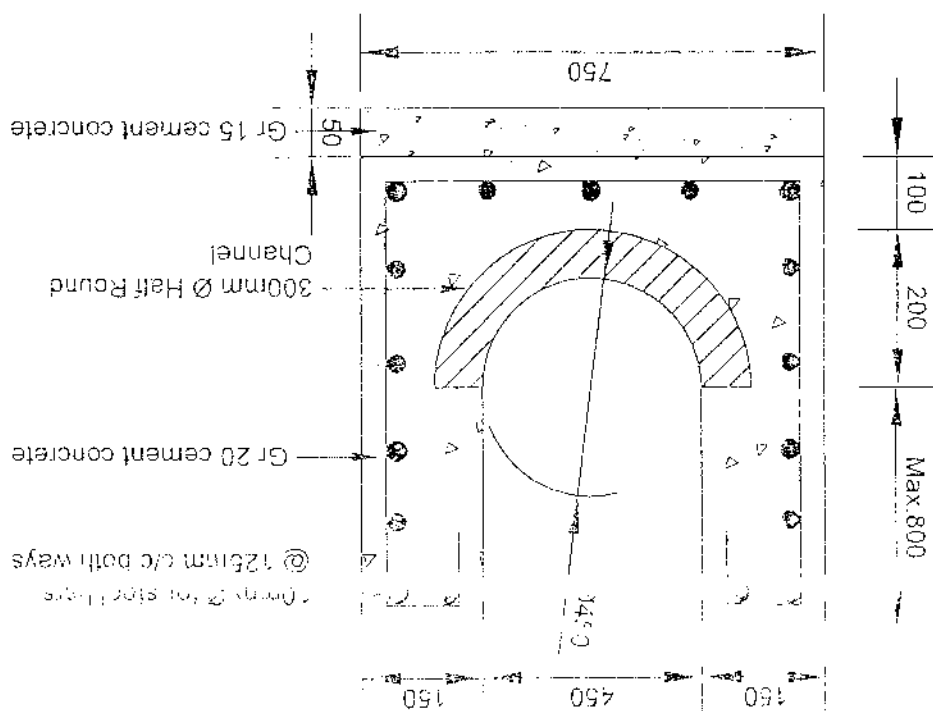

ORIGINAL

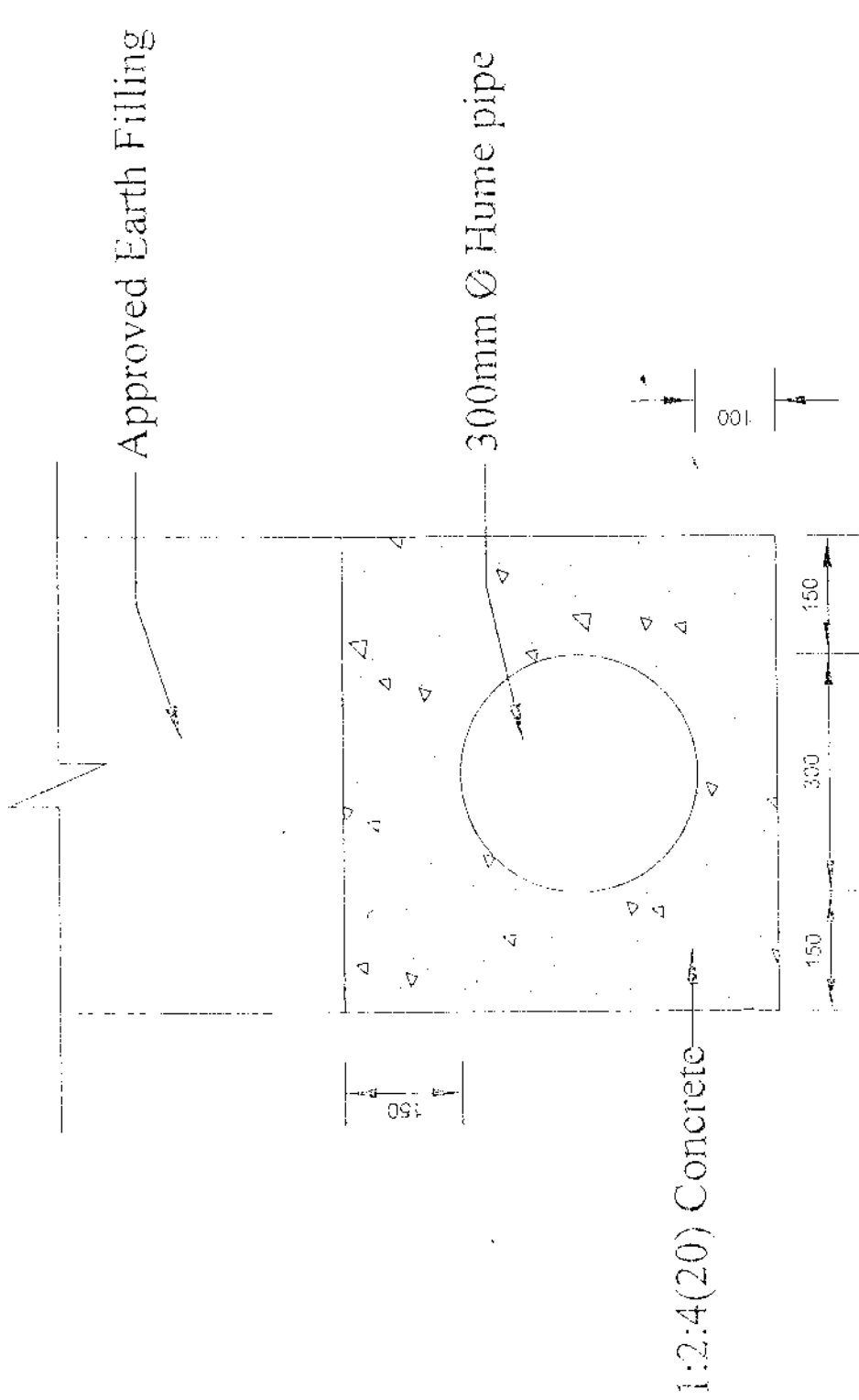

DETAIL OF BED & HAUNCHING AND FILLING

ALL DIMENSIONS ARE IN mm

DRAWING TITLE : DETAIL OF SURROUNDING - 300 mm HUME PIPE

(DRAWING - C)

ORIGINAL

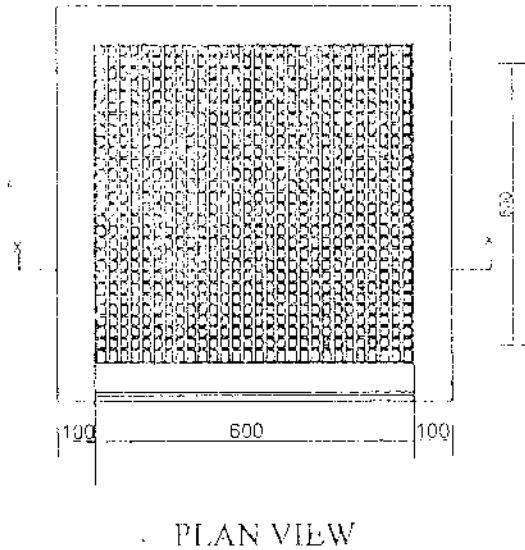
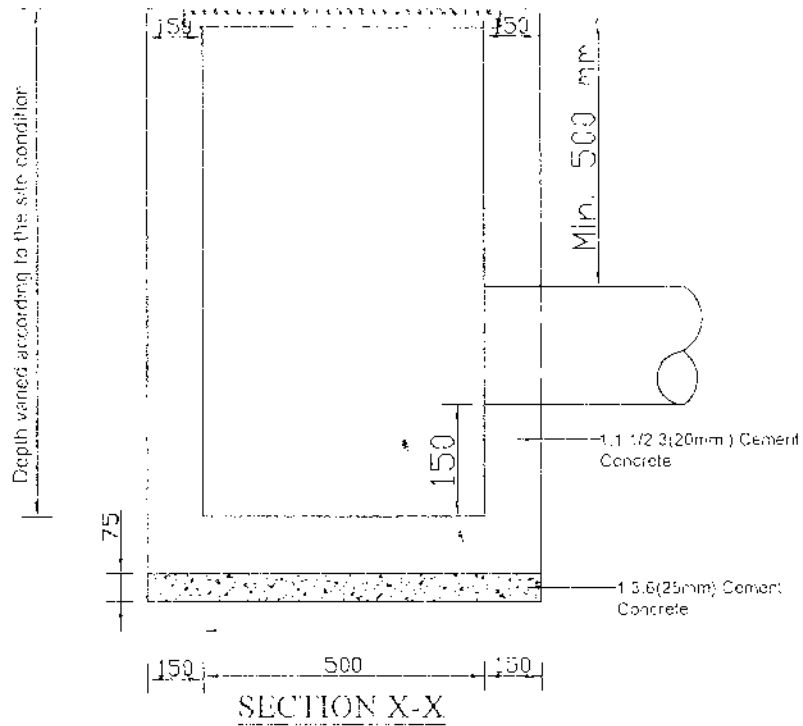

NOTE
ALL DIMENSIONS ARE IN MILLIMETERS

DRAWING TITLE : RAIN WATER GULLY
500 x 500mm

ORIGINAL

SECTION 9
STANDARD FORMS (BID)

Note:

It is the responsibility of bidders to comply with all the requirements given in the bidding document. Failure to non compliance with any of the may be a reason for rejection of the bid.

Notes on Standard Forms:

- Bidders shall submit the completed form of bid security/Bid Securing Declaration as appropriate in compliance with the requirements of the bidding documents.
- Bidders should not complete the Form of Agreement at the time of preparation of bids.
- The successful bidder will be required to sign the Form of Agreement, after the award of contract.
- Any corrections or modifications to the accepted bid resulting from arithmetic corrections, acceptable deviations, or quantity variations in accordance with the requirements of the bidding documents should be incorporated into the Agreement.
- The Form of Performance security, Form of Advance Payment Security and Form of Retention Money Guarantee should not be completed by the bidders at the time of submission of bids.
- The successful bidder will be required to provide these securities in compliance with the requirements herein or as acceptable to the Employer.

FORM OF BID SECURITY

ORIGINAL

40
3

----- [insert issuing agency's name, and address of issuing branch or office]

Beneficiary :Municipal Commissioner, Colombo Municipal Council, Town Hall, Colombo 7

Date :----- [insert (by issuing agency) date]

BID GUARANTEE No: ----- insert (by issuing agency) number]

We have been informed that ----- [insert (by issuing agency) name of the Bidder] (hereinafter called "the Bidder") has submitted to you its bid dated -----] insert (by issuing agency) date] (hereinafter called "the Bid") for improvements to ----- (insert name of contract)for Bids No. ----- (insert reference number of the bid).

Furthermore, we understand that, according to your conditions, Bids must be supported by a Bid Guarantee.

At the request of the Bidder, we ----- [insert name of issuing agency] hereby irrevocably undertake to pay you any sum or sums not exceeding in total an amount of ----- [insert amount in figures] ----- [insert amount on words] upon receipt by us of your first demand in writing accompanied by a written statement stating that the Bidder is in breach of its obligation(s) under the bid conditions, because the Bidder:

- a) Has withdrawn its Bid during the period of bid validity specified; or
- b) Does not accept the correction of errors in accordance with the instructions to Bidders ~~(hereinafter "the ITB"); or~~
- c) Having been notified of the acceptance of its Bid by the Employer during the period of bid validity, (i) fails or refuses to execute the contract Form, if required, or (ii) fails or refuses to furnish the Performance Security, in accordance with the ITB.

This Guarantee shall expire: (a) if the Bidder is the successful bidder, upon our receipt of copies of the Contract signed by the Bidder and of the Performance Security issued to you by the Bidder; or (b) if the Bidder is not the successful bidder, upon the earlier of the successful bidder furnishing the performance security, otherwise it will remain in force up to -----

Consequently, any demand for payment under this Guarantee must be received by us at the office on or before that date.

[signature(s) and name(s) of authorized representative(s)]

39

ORIGINAL

SECTION 10
Other documents

