

106

DUPLICATE

Section - 6

SPECIFICATIONS

**(General specifications have been mentioned in drawings
and Bills of Quantities)**

Work Scope

1. The pumps needs to be dismantle, repair/service and re install at the site.
2. The lubricants should be changed.
3. Balancing shall be done prior to install.
4. The following kits need to be replacing with new one.
 - Primary seal
 - Secondary seal
 - O' ring
 - Moisture switch
 - Lower bearing
 - Upper bearing
 - impeller O' ring
 - Temperature sensor PT100 f. bearings fr74
 - Volute casing with complete accessories to fix the pump to the line
5. Shaft Rotor shall be replace with the approval of the engineer.
6. The manufacturer's recommended spare parts should be delivered with the pump for 2 years operation.

The accessories such as Nuts, Bolts, Washers, thread bars, extension kit, base plate etc. whichever needs for the complete installation of pumps should be supply by the contractor. The free maintenance period shall be 6 months and the defect liability period shall be 2 years. The contractor should be contactable on 24/7 for any repairs that liable to the contractor throughout the defect liability period and the required works need to be attended within 12 hours. The maintenance period and the defect liability period shall be start from the date of completion of total work. The contractor shall have a permanent office and workshop in the vicinity to the site and the repair kits for the pump should be available there at any time.

The Contractor shall submit the work program and technical details relevant to the work for prior approval of the engineer.

The replaced parts should be handed over to the employer to complete the work.

The contractor should carry out any work related to the above Contract with prior approval from the Engineer.

DUPLICATE

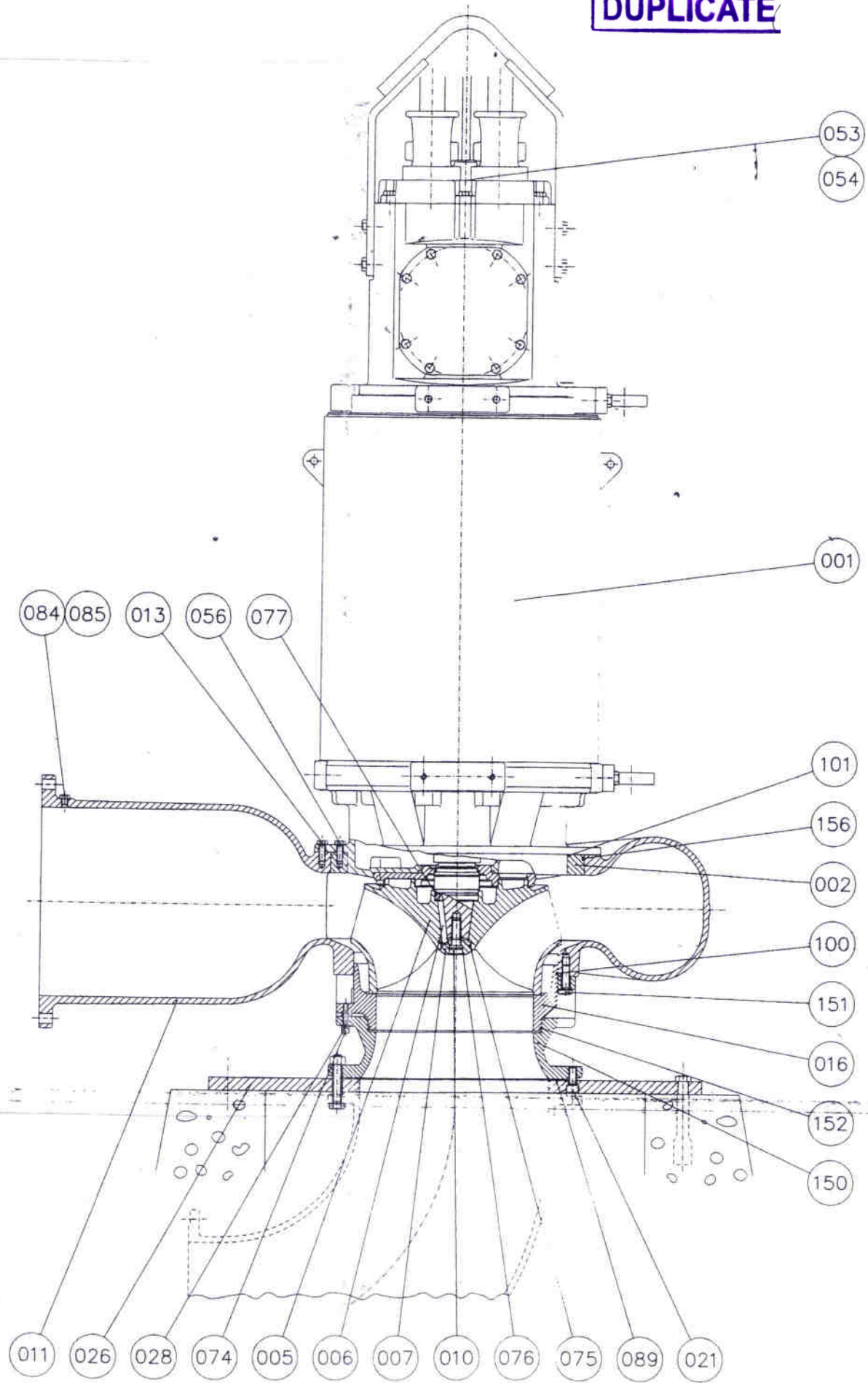

Assembly drawing		X	
Pump		A-944987	
№ 7.2000	№ 13.2.000	№ 13.2.000	№ 13.2.000
1:5	1:5	1:5	1:5

DUPLICATE

Index_4 b_96585161 pump parts.xls

SortStrng	Component number	Object description	Qty (CQt)	Un
001	96585430	Motor unit fr.74 (96585161/S33006L3511Z)	1.000	PC
002	96237596	Intermediate ring 34581, fr.74	1.000	PC
005	96585419	Impeller 11542Z, mach. fr.74	1.000	PC
006	96068123	Key 32671	1.000	PC
007	96067603	Impeller cap 13957	1.000	PC
010	96068122	Screw 32670	1.000	PC
011	96236803	Volute casing 131016, mach. fr.74	1.000	PC
013	96060810	Hex screw M16x45-FMSR16045	12.000	PC
016	96236804	Suction Cover, mach fr.70	1.000	PC
021	96060857	Allen-head screw M20x50 FMSS20050	4.000	PC
026	96236806	Baseplate 131019, mach. fr.74	1.000	PC
028	96238894	Hexagonal screw m12x60	6.000	PC
053	96066955	Rating plate zz244	2.000	PC
054	96060663	Screw nail n2,5x5 FCUA02505	4.000	PC
056	96060810	Hex screw M16x45 FMSR16045	12.000	PC
074	96464536	Adjusting Screw M20 60532716	3.000	PC
075	96066633	O-ring 69,2x5,7 NBR YJOR069257	1.000	PC
076	96066621	O-ring 29,2x3,0 NBR YJOR029230	1.000	PC
077	96066638	O-ring 104,1x5,7 NBR YJOR104157	1.000	PC
084	96068291	Plug R3/8" 60534041	1.000	PC
085	96066617	O-ring 16,3x2,4 NBR YJOR016324	1.000	PC
089	96060969	Flange seal DN500 PN10 gtaa5001030as	1.000	PC
100	96066694	O-ring 499,3x5,7 NBR YJOR499357	1.000	PC
101	96066697	O-ring 557,7x7,0 YJOR557770	1.000	PC
150	96236805	Flange 131018, mach. fr.74	1.000	PC
151	96060748	Hex screw M20x70 FMHR20070	6.000	PC
152	96066690	O-ring 419,3x5,7 NBR YJOR419357	1.000	PC
156	96066700	O-ring 647,1 x 7,0 YJOR647170	1.000	PC
	96237851	Low loader 861053	1.000	PC
	96585520	Cable rack	1.000	PC
	96585379	Wooden cage (3100x1400x2000 mm)	1.000	PC

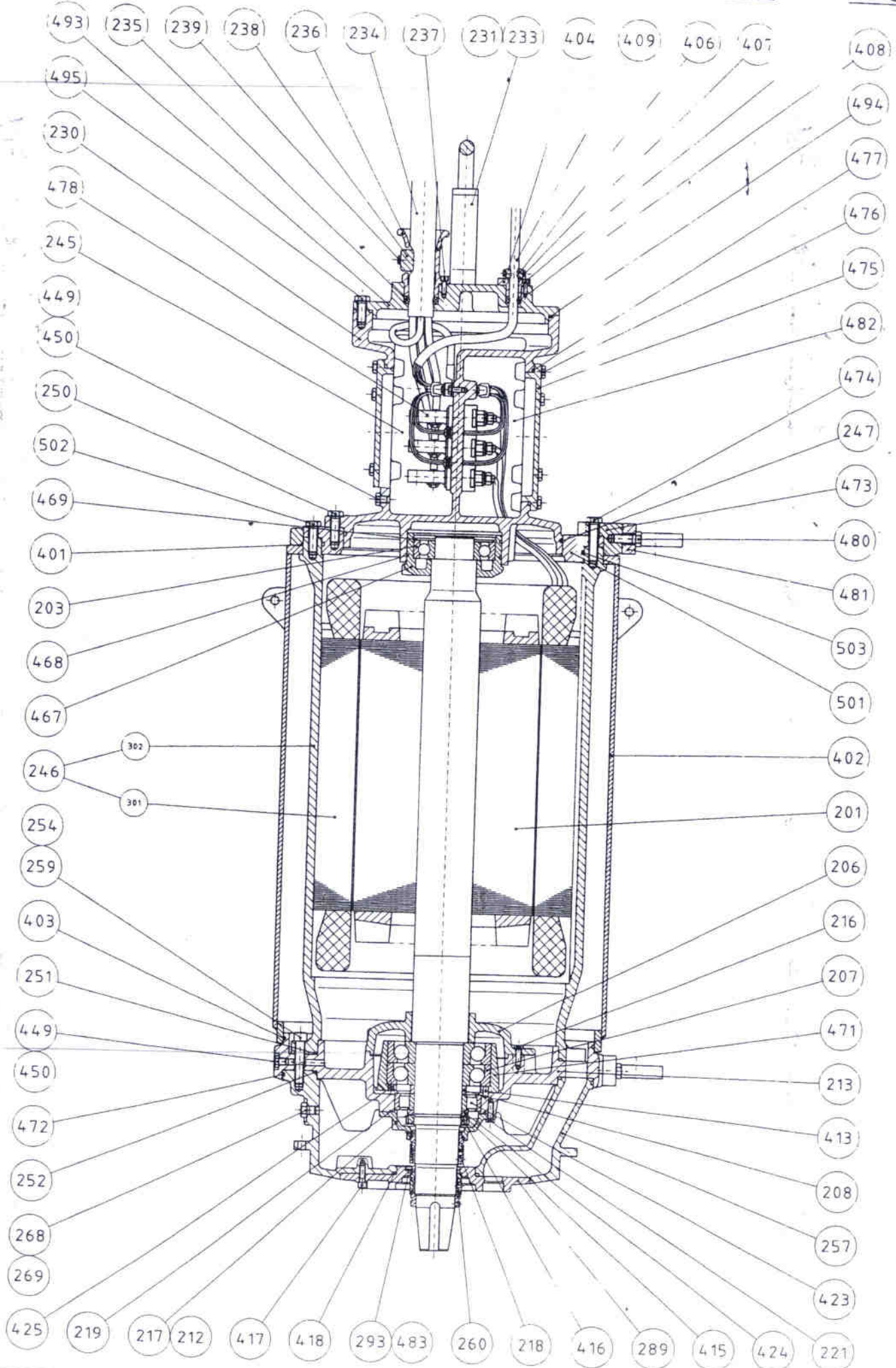

Assembly drawing
 Motor
 14
 A-945110

SortStrng	Component number	Object description	Qty (CQt)	Un
201	96249594	Rotor fr. 74		
203	96061643	Ball bearing SKVL6318C3	1.000	PC
206	96482735	Bearing bracket cover 194983	1.000	PC
207	96061648	Angular contact ball bearing SKVL7322BG	2.000	PC
208	96067860	Washer 194994	1.000	PC
212	96060625	Taper pin FABK04020	1.000	PC
213	96237220	Lower bearing bracket 194981, mach. fr74	1.000	PC
216	96060798	Hex screw M12x35 FMSR12035	3.000	PC
217	96237222	Bearing bracket cover 194982, mach. fr74	1.000	PC
218	96526002	Secondary shaft seal fr.74 - YJ34610100	1.000	PC
219	96066735	O-ring 209,3x5,7 viton FB YJOV209357	1.000	PC
221	96060798	Hex screw M12x35 FMSR12035	3.000	PC
230	96237294	Junction box 196063, mach. fr. 74	1.000	PC
231	96237230	Lifting handle 195004, fr.74	1.000	PC
233	96060811	Hex screw M16x50 FMSR16050	4.000	PC
234	96248052	Cable 4 x 95 mmý 25 M	4.000	PC
235	96066560	Rubber seal lv. m6,m2 YJK192492	4.000	PC
236	96067783	Cable inlet EXd 4x95mm2 192846	4.000	PC
237	96060838	Allen-head screw M10x30 FMSS10030	12.000	PC
238	96067650	Cable clamp 191097	4.000	PC
239	96060790	Hex screw M10x55 FMSR10055	8.000	PC
245	96255546	Connector set (4x4x95 + 10x2.5/2.5)	1.000	PC
246	96585438	Stator in housing cpl, fr.74	1.000	PC
247	96066692	O-ring 481,5x7,0 NBR YJOR481570	1.000	PC
250	96060821	Hex screw M20x60 FMSR20060	8.000	PC
251	96066696	O-ring 541,0x7,0 YJOR541070	1.000	PC
252	96066696	O-ring 541,0x7,0 YJOR541070	1.000	PC
254	96060858	Allen-head screw M20x100 FMSS20100	12.000	PC
257	96237219	Seal housing 194979, mach. fr. 74	1.000	PC
259	96238894	Hexagonal screw m12x60	2.000	PC
260	96496824	Primary shaft seal fr. 74 - YJ3460995	1.000	PC
268	96068156	Plug 34547	3.000	PC
269	96462218	O-ring YJOR026230	3.000	PC
289	96249306	Oil housing cover 195823, mach, fr. 74	1.000	PC
293	96068157	Locking pin 34549	1.000	PC
401	96066699	O-ring 596,3x7,0 YJOR596370	1.000	PC
402	96249416	Cooling jacket 196057, fr.74	1.000	PC
403	96066702	O-ring 699,0x7,0 YJOR699070	1.000	PC
404	96067769	Cable inlet EXd d=31mm 192716	1.000	PC
405	96060838	Allen-head screw M10x30 FMSS10030	3.000	PC
406	96067630	Cable clamp 191033	2.000	PC
407	96060778	Hex screw M8x40 FMSR08040	2.000	PC
408	96066562	Rubber seal lv. m6,m2 YJK192717a	1.000	PC
409	96585474	EMC cable 10x2.5/2.5 mmý 25 M	1.000	PC
413	96060626	Cylinder pin 12x24 FABL12024	1.000	PC
415	96061615	Lock washer SKVLmb22	1.000	PC
416	96061610	Nut SKVLkm22	1.000	PC
417	96060842	Allen-head screw M12x40 FMSS12040	4.000	PC
418	96066666	O-ring 181,0x7,0 NBR YJOR181070	1.000	PC
423	96061618	Roller bearing SKVLnu222ec	1.000	PC
424	96061605	Angle ring SKVLhj222ec	1.000	PC
425	96060606	Spring EJkd45121	6.000	PC
428	96249307	Air pipe 196066, fr. 74	1.000	PC
449	96068291	Plug R3/8" 60534041	2.000	PC
450	96066617	O-ring 16,3x2,4 NBR YJOR016324	2.000	PC

DUPLICATE

05

Index_5 b_96585430 motor parts (pump 96585161).xls

SortStrng	Component number	Object description	Qty (CQt)	Un
467	96467275	Upper bearing bracket 194986	1.000	PC
468	96066735	O-ring 209,3x5,7 viton FB YJOV209357	2.000	PC
469	96482736	Circlip fadc190	1.000	PC
471	96067859	Locking ring 194984	1.000	PC
472	96066702	O-ring 699,0x7,0 YJOR699070	1.000	PC
473	96237293	Locking ring 196058	1.000	PC
474	96060821	Hex screw M20x60 FMSR20060	8.000	PC
475	96237295	Junction box cover, 196064, mach. fr. 74	2.000	PC
476	96060809	Hex screw M16x40 FMSR16040	16.000	PC
477	96066680	O-ring 285,1x7,0 YJOR285170	2.000	PC
478	96242459	Junction plate fr74	1.000	PC
480	96060821	Hex screw M20x60 FMSR20060	4.000	PC
481	96237229	Lifting lug 194997	2.000	PC
482	96242610	Protection equipment for assembly	1.000	PC
483	96060867	Cylindric screw M5x8 Zn FMTH05008	1.000	PC
493	96249308	Motor cover 196085, mach, fr. 74	1.000	PC
494	96066689	O-ring 405,3x7,0 YJOR405370	1.000	PC
495	96060820	Hex screw M20x50 FMSR20050	6.000	PC
496	96477404	Oil indicator 30 m cable oct3460430	1.000	PC
501	96237281	Intermediate ring 195924, mach. fr. 74	1.000	PC
502	96060821	Hex screw M20x60 FMSR20060	8.000	PC
503	96066698	O-ring 582,7x7,0 YJOR582770	1.000	PC

* see separate lists & drawings